

CLASSE H3 SPARTITRAFFICO - BARRIERA 3 ONDE W6

Class H3 Double sided - 3-waves guardrail W6
 3 Wellen Leitplanke für den Mittelstreifen, Aufhaltestufe H3, Wirkungsbereich W6
 Classe H3 Glissière centrale - Glissière 3 ondes simple W6
 Clase H3 Paso de mediana - Barrera de triple onda simple W6

H3-W6

3-waves

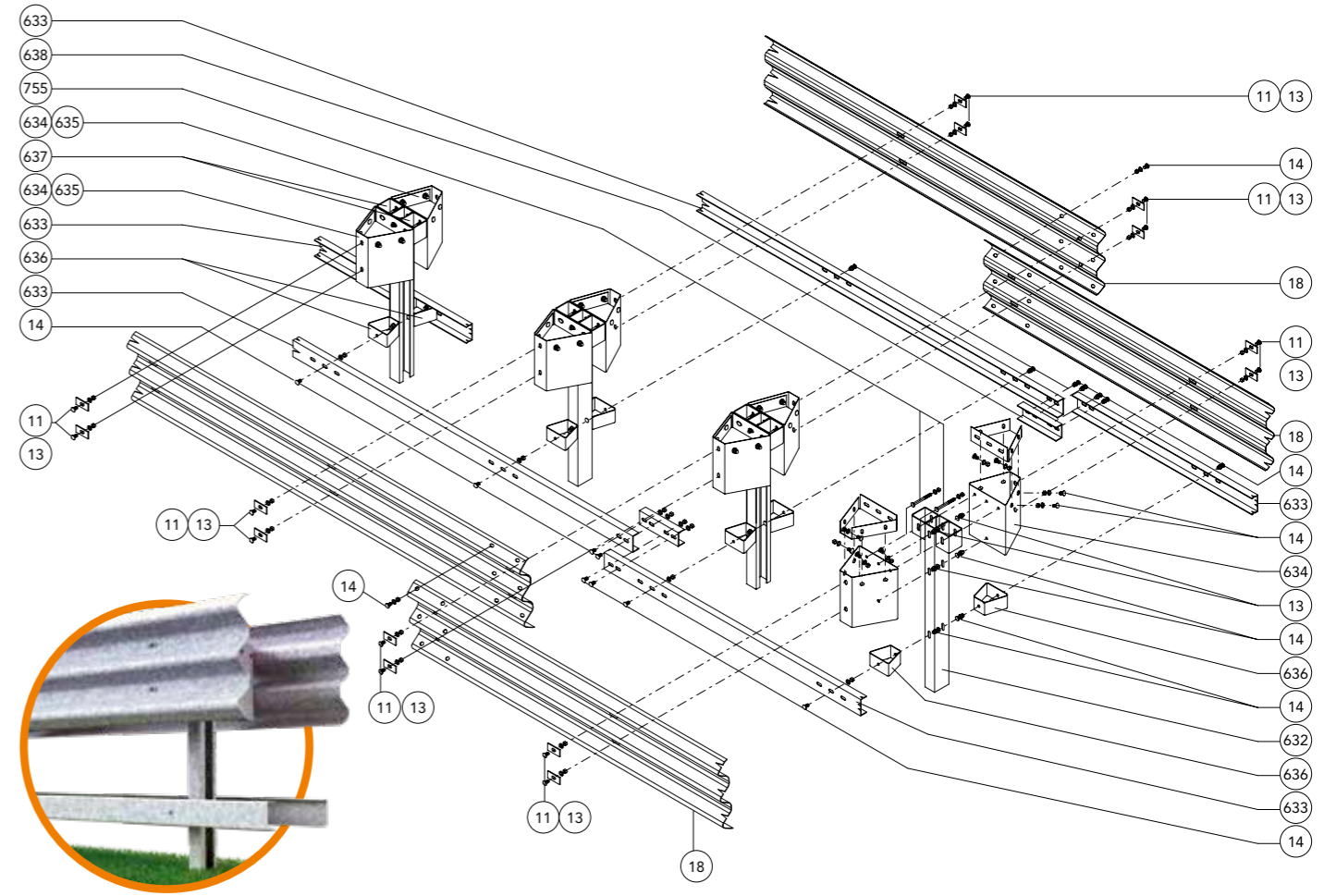
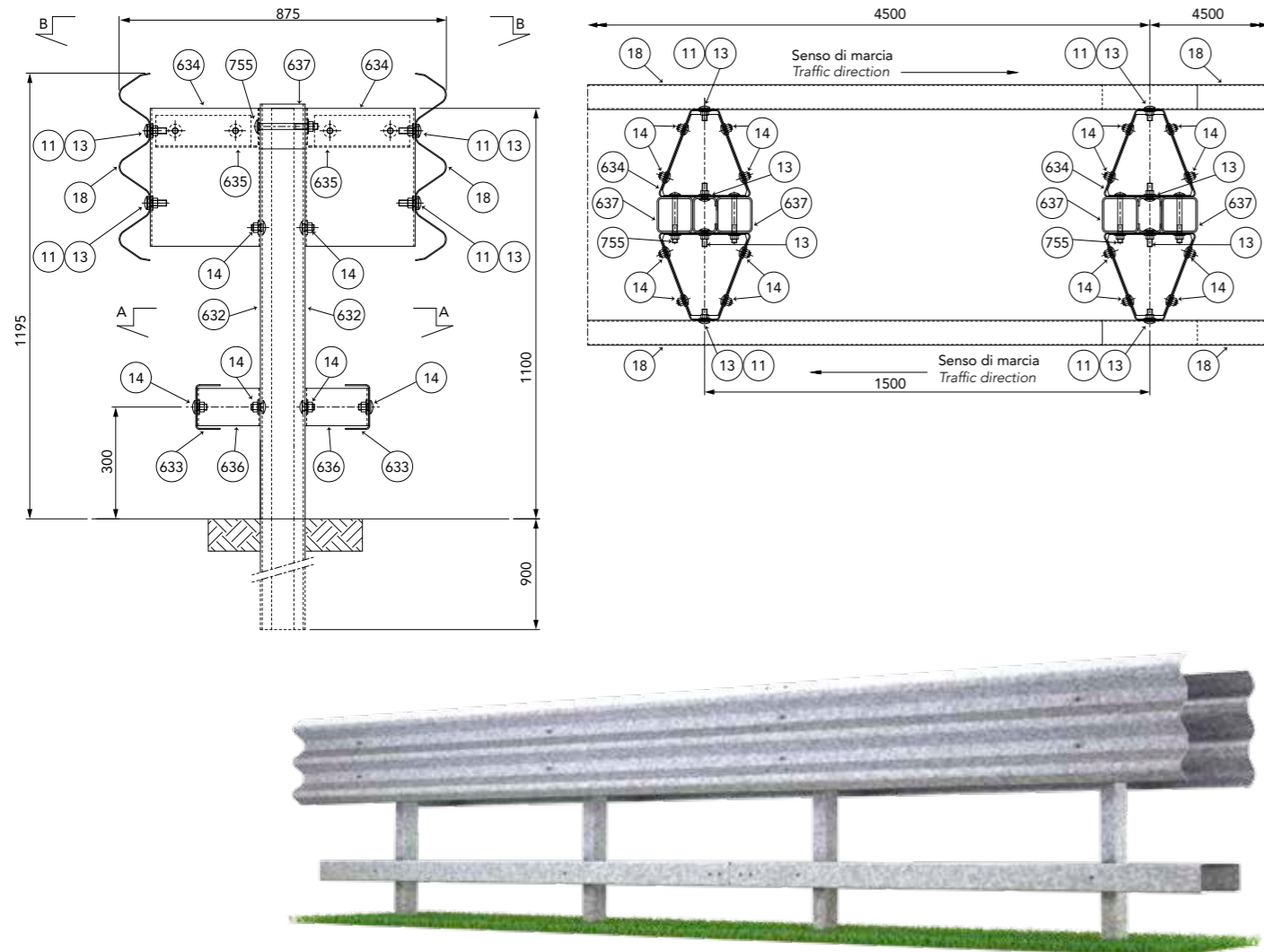

Caratteristiche Characteristics, Eigenschaften, Caractéristiques, Características	
Altezza fuori terra Height above ground level, Höhe über Grundboden, Hauteur hors sol, Altura sobre el suelo	1195 ± 50 mm
Profondità d'infissione Depth of penetration, Rammtiefe, Profondeur de piling du poteau, Longitud hincada	900 mm
Ingombro trasversale Overall width, Gesamtbreite, Grosseur hors tout, Anchura total	875 mm
Interasse pali Post spacing, Steherabstand, Distance entre poteaux, Distancia entre postes	1500 mm

Rapporti di prova Crash test reports, Testberichte, Comptes rendus d'essais, Relaciones de pruebas											
Test n.	Facility	Test	Type	Barrier length m	Mass kg	Speed km/h	ASI max 1.4	THIV max 33 km/h	D m	Vi m	W m
PROVA 635	Aisico	TB61	Laterale 20°	90	16.000	20	-	-	1,7	2,10	2,1=W6
PROVA 633	Aisico	TB11	Laterale 20°	90	900	100	1=A	29	0,4	-	1,2=W4

Componenti Components, Bauteile, Composants, Elementos			
	Descrizione Description		Materiale Material
755	Bullone completo Bolt with nut and washer, Schraube komplett, Boulon complet, Tornillo completo con tuerca y arandela	M16x160 mm	Classe 8.8
638	Manicotto di giunzione per corrente Coupling box rear reinforcement, Verbindungsmuffe für Längsträger, Jonction poutre, Conector		S 235 JR
637	Tubo quadro antirotazione Anti-rotation square tube, Anti-Rotations-Vierkanrohr, Tube carré antirotation, Tubo cuadrado anti-rotación	120x120 Th=5 H=120 mm	S 235 JR
636	Distanziatore trapezoidale inferiore Trapezoidal lower spacer, Unterer trapezförmiger Abstandhalter, Entretoise trapézoïdale inférieure, Separador trapezoidal inferior		S 275 JR
635	Piastra di chiusura superiore Upper covering plate, Obere Abdeckplatte, Plaque de recouvrement supérieure, Placa de cierre superior		S 235 JR
634	Distanziatore trapezoidale superiore Trapezoidal upper spacer, Oberer trapezförmiger Abstandhalter, Entretoise trapézoïdale supérieure, Separador trapezoidal superior		S 235 JR
633	Corrente "U" U-rear reinforcement, U-Längsträger, Poutre en U, Larguero "U"	120x65 Th=3 L=4490 (1500x3) mm	S 235 JR
632	Palo "C" C-post, C-Steher, Poteau en C, Poste "C"	120x80x30 Th=5 H=2000 mm	S 235 JR
18	Fascia 3 onde 3-waves beam, 3-wellige Leitschiene, Glissière 3 ondes, Banda triple onda	L=4816 (1500x3) Th=3 mm	S 235 JR
14	Bullone completo Bolt with nut and washer, Schraube komplett, Boulon complet, Tornillo completo con tuerca y arandela	M16x30 mm	Classe 8.8
13		M16x50 mm	Classe 8.8
11	Piastrina copriasola Slot covering plate, Lochabdeckplatte, Plaque de couverture fente, Placa cubre-ranura	100x40x4 mm	S 275 JR