

## CLASSE H2 BORDO LATERALE - BARRIERA 3 ONDE SINGOLA SU RILEVATO W5

Class H2 Roadside - 3-waves single sided guardrail W5  
 Gerammte 3 Wellen Leitplanke, Aufhaltestufe H2, Wirkungsbereich W5  
 Classe H2 Bord latéral - Glissière 3 ondes simple sur remblai W5  
 Clase H2 Borde lateral - Barrera de triple onda simple sobre base terreno W5

# H2-W5

## 3-waves

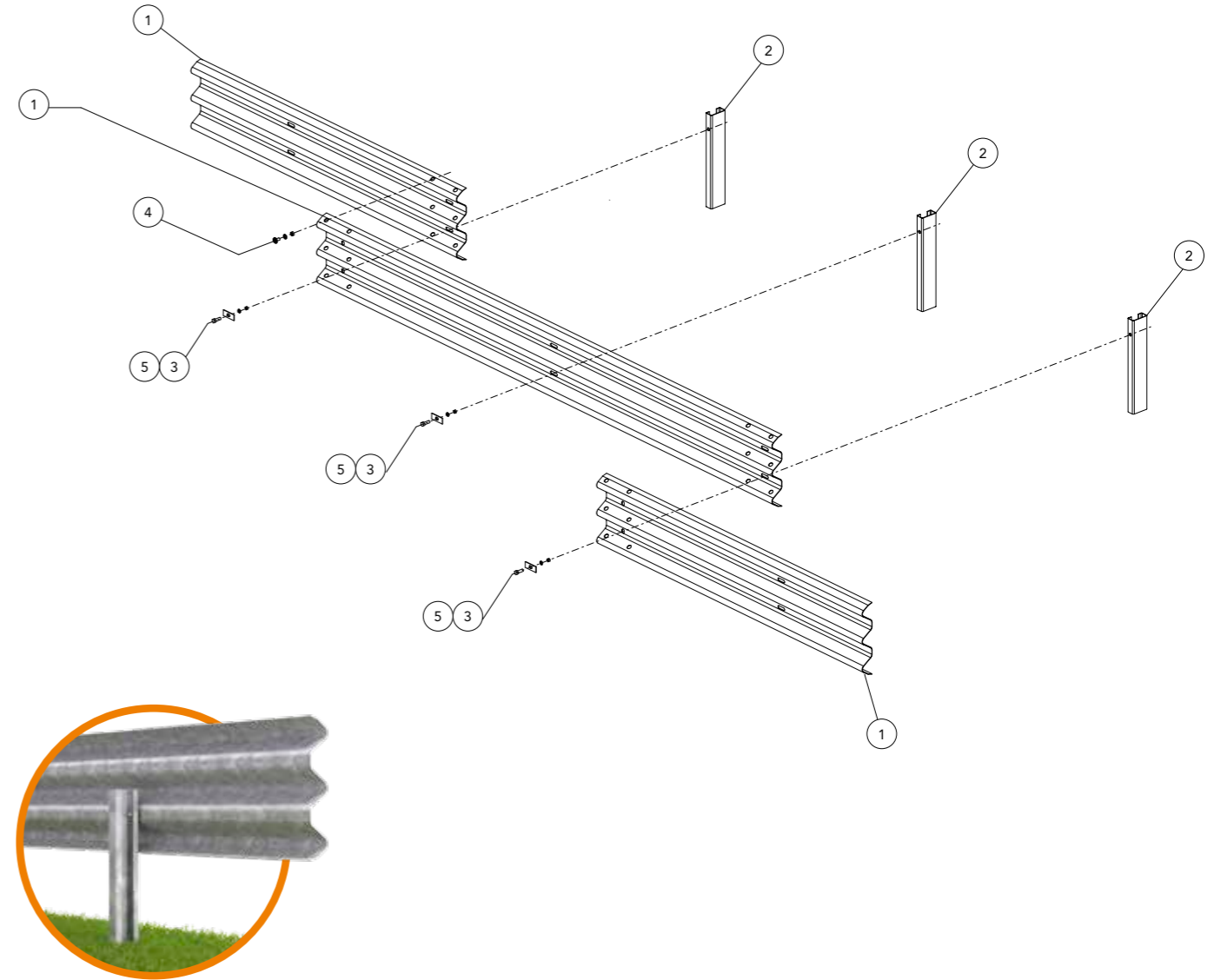
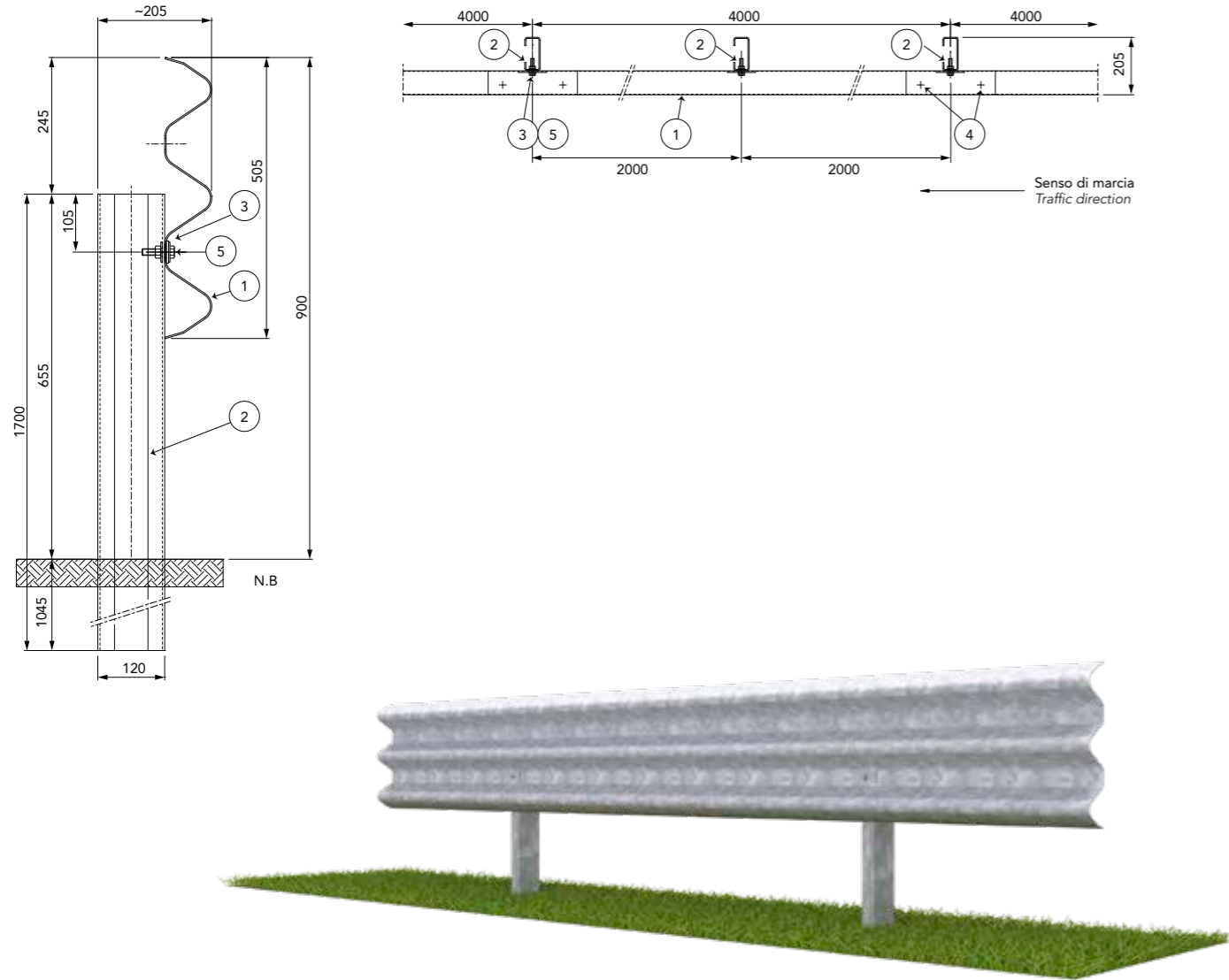

### Caratteristiche Characteristics, Eigenschaften, Caractéristiques, Características

<b>Altezza fuori terra</b> Height above ground level, Höhe über Grundboden, Hauteur hors sol, Altura sobre el suelo	900 mm
<b>Profondità d'infissione</b> Depth of penetration, Rammtiefe, Profondeur de piling du poteau, Longitud hincada	1045 mm
<b>Ingombro trasversale</b> Overall width, Gesamtbreite, Grosseur hors tout, Anchura total	205 mm
<b>Interasse pali</b> Post spacing, Steherabstand, Distance entre poteaux, Distancia entre postes	2000 mm

### Rapporti di prova Crash test reports, Testberichte, Comptes rendus d'essais, Relaciones de pruebas

Test n.	Facility	Test	Type	Barrier length MTL	Mass kg	Speed km/h	ASI max 1.4	THIV max 33 km/h	D m	Vi m	W m
PROVA 1058	Aisico	TB51	Laterale 20°	72,00	13.000	70	-	-	1,5	1,7	1,6=W5
PROVA 1050	Aisico	TB11	Laterale 20°	72,00	900	100	0,9=A	28	0,4	-	0,5=W1

### Componenti Components, Bauteile, Composants, Elementos

	Descrizione Description		Materiale Material
5	<b>Bullone completo + rondella</b> Bolt with nut and washer + washer, Schraube komplett + unterlegscheibe, Boulon complet + rondelle, Tornillo completo con tuerca y arandela + arandela	M12x50 mm	Classe 8.8
4	<b>Bullone completo</b> Bolt with nut and washer, Schraube komplett, Boulon complet, Tornillo completo con tuerca y arandela	M16x30 mm	Classe 8.8
3	<b>Piastrina copriasola</b> Slot covering plate, Lochabdeckplatte, Plaque de couverture fente, Placa cubre-ranura	100x40x4 mm	S 275 JR
2	<b>Palo "C"</b> C-post, C-Steher, Poteau en C, Poste "C"	120x55x30 Th=4 H=1700 mm	S 275 JR
1	<b>Fascia 3 onde</b> 3-waves beam, 3-wellige Leitschiene, Glissière 3 ondes, Banda triple onda	L=4316 Th=2,5 mm	S 275 JR