

CLASSE H2 BORDO LATERALE - BARRIERA 3 ONDE SINGOLA SU RILEVATO W4 CON ARGINELLO

Class H2 Roadside - 3-waves single sided guardrail W4, on shoulder

Gerammte 3 Wellen Leitplanke, Aufhaltestufe H2, Wirkungsbereich W4, auf dem Bankett

Classe H2 Bord latéral - Glissière 3 ondes simple sur remblai W4, avec terre-plein

Clase H2 Borde lateral - Barrera de triple onda simple sobre base terreno W4, con terraplén

H2-W4

3-waves 2020

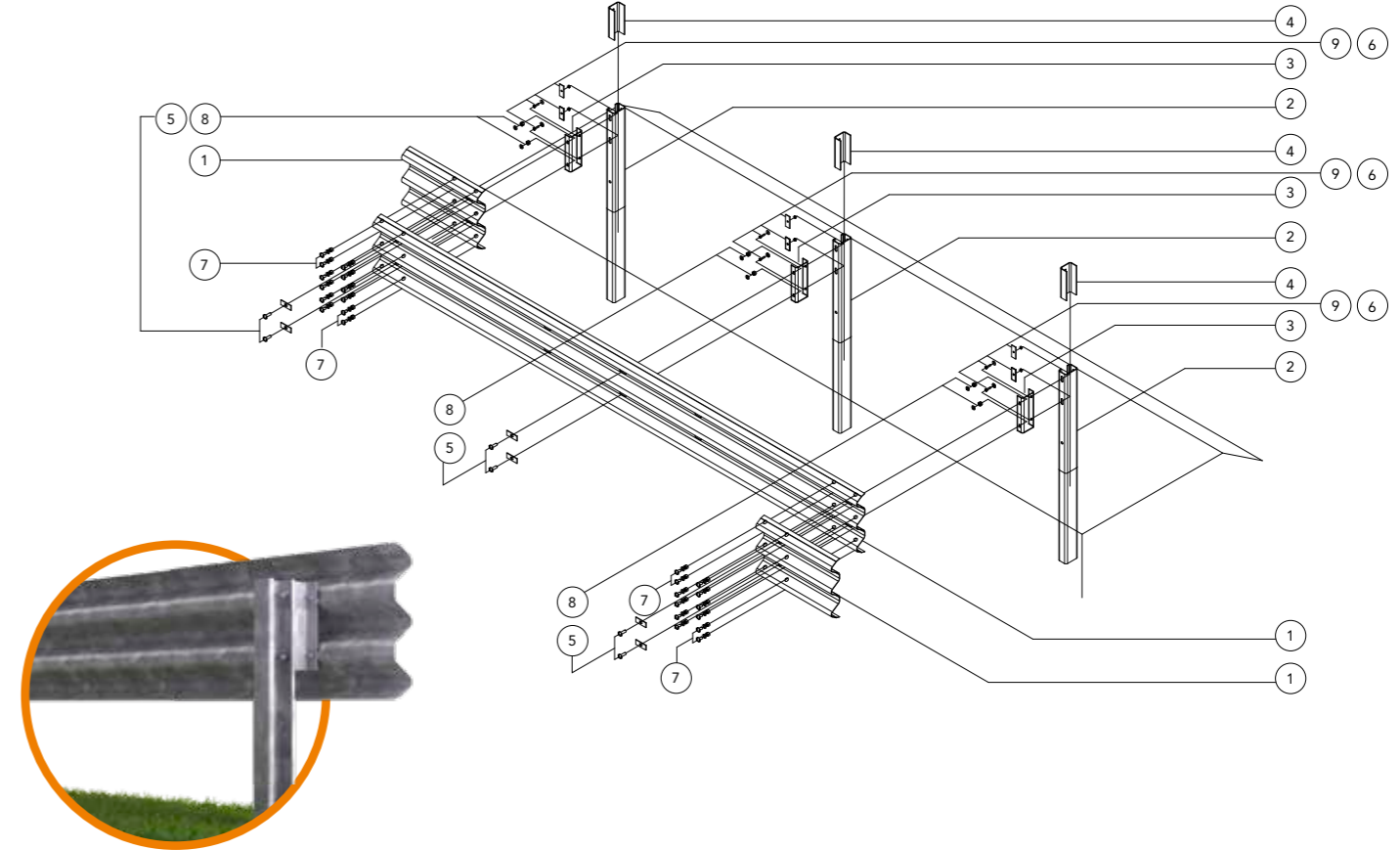
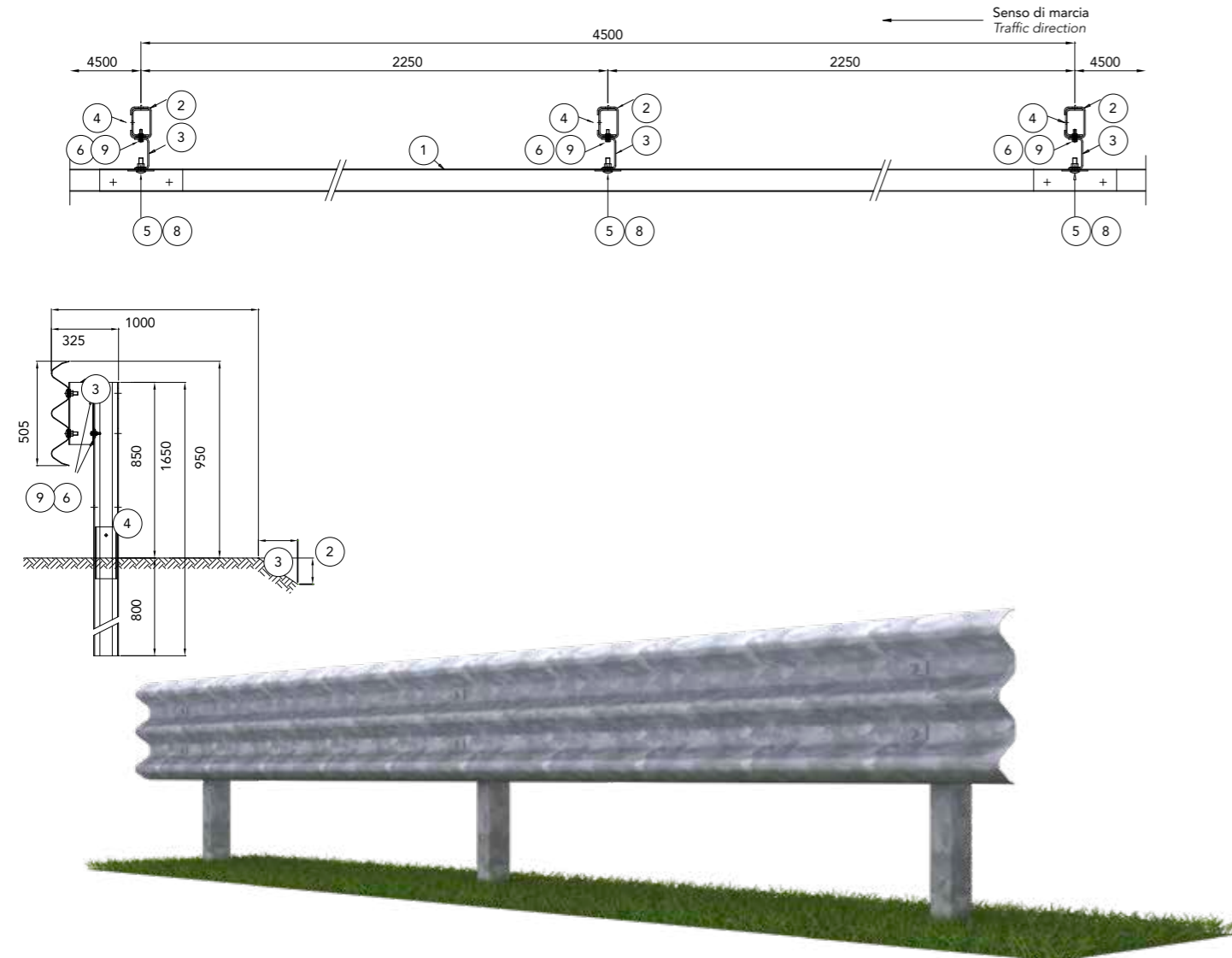

Caratteristiche Characteristics, Eigenschaften, Caractéristiques, Características	
Altezza fuori terra Height above ground level, Höhe über Grundboden, Hauteur hors sol, Altura sobre el suelo	950 mm
Profondità d'infissione Depth of penetration, Rammtiefe, Profondeur de piling du poteau, Longitud hincada	800 mm
Ingombro trasversale Overall width, Gesamtbreite, Grosseur hors tout, Anchura total	325 mm
Interasse pali Post spacing, Steherabstand, Distance entre poteaux, Distancia entre postes	2250 mm

Rapporti di prova Crash test reports, Testberichte, Comptes rendus d'essais, Relaciones de pruebas											
Test n.	Facility	Test	Type	Barrier length MTL	Mass kg	Speed km/h	ASI max 1.4	THIV max 33 km/h	D m	Vi m	W m
PROVA 1988	AISICO	TB51	Laterale 20°	63,00	13000	70	-	-	1,2	1,3=V14	1,3=W4
PROVA 1996	AISICO	TB11	Laterale 20°	63,00	900	100	1=A	31	0,4	-	0,7=W2

Componenti Components, Bauteile, Composants, Elementos			
Descrizione - barriera in acciaio zincato Description - galvanized steel barrier			Materiale Material
9	Bullone completo Bolt with nut and washer, Schraube komplett, Boulon complet, Tornillo completo con tuerca y arandela	M10x40 mm	Classe 6.8
8		M16x50 mm	Classe 8.8
7		M16x30 mm	Classe 8.8
6	Piastrina Plate, Plättchen, Platine, Platina	M10 100x40 Th=4 mm	S 275 JR
5	Piastrina copriasola Slot covering plate, Lochabdeckplatte, Plaque de couverture fente, Placa cubre-ranura	100x40 Th=4 mm	S 275 JR
4	Elemento a "U" "U" Element, Element "U", Élément "U", Elemento "U"	104x65 Th=5 L=250 mm	S 275 JR
3	Distanziatore "U" U-Spacer, U-Abstandhalter, Entretoise U, Separador "U"	120x55 Th=5 L=300 mm	S 275 JR
2	Palo "C" C-post, C-Steher, Poteau en C, Poste "C"	120x80x30 Th=5 L=1650 mm	S 275 JR
1	Fascia 3N 3N beam, 3N Leitschiene, Glissière 3N, Banda 3N	L=4816 Th=2.5 mm	S 355 JR
Descrizione - barriera in acciaio corten Description - corten steel barrier			Materiale Material
9	Bullone completo Bolt with nut and washer, Schraube komplett, Boulon complet, Tornillo completo con tuerca y arandela	M10x40 mm	Tropicaliz.
8		M16x50 mm	Tropicaliz.
7		M16x30 mm	Tropicaliz.
6	Piastrina Plate, Plättchen, Platine, Platina	M10 100x40 Th=4 mm	S 355 JOWP
5	Piastrina copriasola Slot covering plate, Lochabdeckplatte, Plaque de couverture fente, Placa cubre-ranura	100x40 Th=4 mm	S 355 JOWP
4	Elemento a "U" "U" Element, Element "U", Élément "U", Elemento "U"	104x65 Th=5 L=250 mm	S 355 JOWP
3	Distanziatore "U" U-Spacer, U-Abstandhalter, Entretoise U, Separador "U"	120x55 Th=5 L=300 mm	S 355 JOWP
2	Palo "C" C-post, C-Steher, Poteau en C, Poste "C"	120x80x30 Th=5 L=1650 mm	S 355 JOWP
1	Fascia 3N 3N beam, 3N Leitschiene, Glissière 3N, Banda 3N	L=4816 Th=2.50 mm	S 355 JOWP