

CLASSE H2 SPARTITRAFFICO - BARRIERA 2 ONDE W4

Class H2 Double sided - 2-waves guardrail W4

Doppel-Wellen Leitplanke für den Mittelstreifen, Aufhaltestufe H2, Wirkungsbereich W4

Classe H2 Glissière centrale - Glissière 2 ondes simple W4

Clase H2 Paso de mediana - Barrera de doble onda simple W4

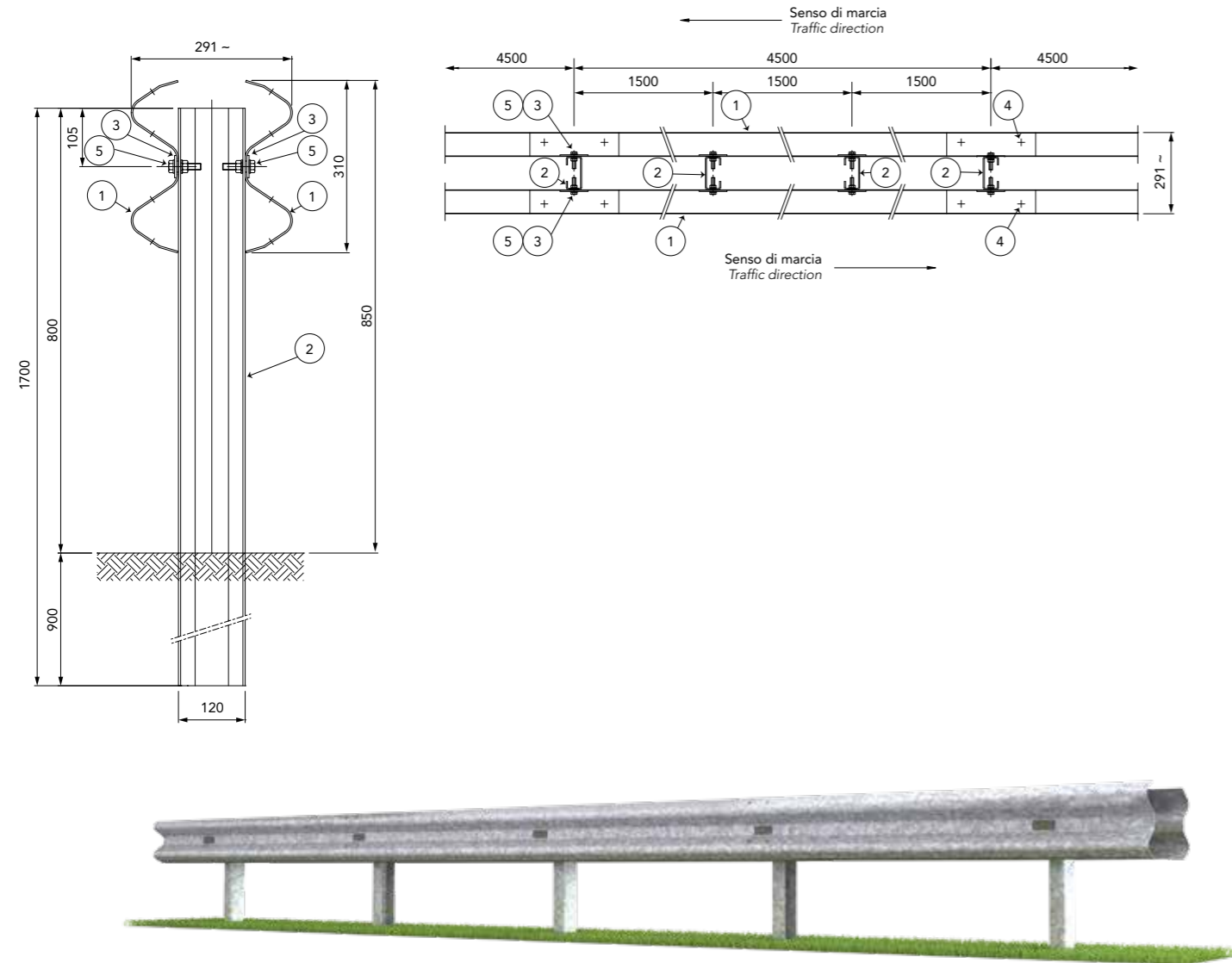

H2-W4

2-waves

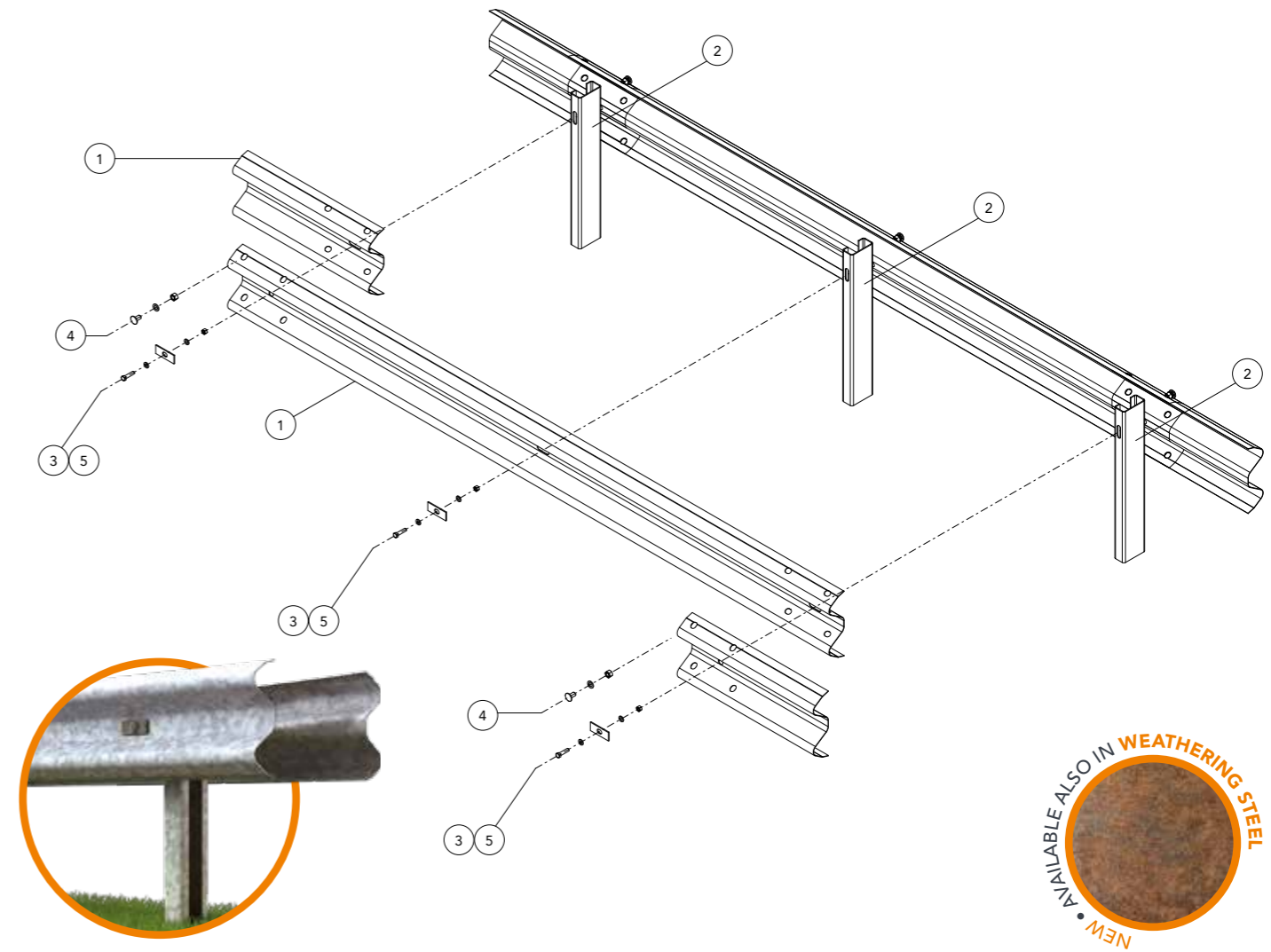

Caratteristiche Characteristics, Eigenschaften, Caractéristiques, Características

Altezza fuori terra Height above ground level, Höhe über Grundboden, Hauteur hors sol, Altura sobre el suelo	850 mm
Profondità d'infissione Depth of penetration, Rammtiefe, Profondeur de piling du poteau, Longitud hincada	900 mm
Ingombro trasversale Overall width, Gesamtbreite, Grosseur hors tout, Anchura total	291 mm
Interasse pali Post spacing, Steherabstand, Distance entre poteaux, Distancia entre postes	1500 mm

Rapporti di prova Crash test reports, Testberichte, Comptes rendus d'essais, Relaciones de pruebas

Test n.	Facility	Test	Type	Barrier length m	Mass kg	Speed km/h	ASI max 1.4	THIV max 33 km/h	D m	Vi m	W m
PROVA 954	Aisico	TB51	Laterale 20°	90	13000 (bus)	70	-	-	1,2	1,7	1,3=W4
PROVA 960	Aisico	TB11	Laterale 20°	90	900 (car)	100	1,1=B	33	0,3	-	0,6=W1

Componenti Components, Bauteile, Composants, Elementos

Descrizione - barriera in acciaio zincato Description - galvanized steel barrier		Materiale Material	
5	Bullone completo Bolt with nut and washer, Schraube komplett, Boulon complet, Tornillo completo con tuerca y arandela	M12x50 mm	Classe 8.8
4		M16x30 mm	Classe 8.8
3	Piastrina copriasola Slot covering plate, Lochabdeckplatte, Plaque de couverture fente, Placa cubre-ranura	100x40x4 mm	S 275 JR
2	Palo "C" C-post, C-Steher, Poteau en C, Poste "C"	120x55x30 Th=4 L=1700 mm	S 275 JR
1	Fascia 2 onde 2-waves beam, 2-wellige Leitschiene, Glissière 2 ondes, Banda doble onda	L=4816 (1500x3) Th=2,85 mm	S 355 JR

Componenti Components, Bauteile, Composants, Elementos

Descrizione - barriera in acciaio corten Description - corten steel barrier		Materiale Material	
5	Bullone completo + 2 rondelle Bolt with nut and washer + 2 washers, Schraube komplett + 2 scheibe, Boulon complet + rondelle, Tornillo completo con tuerca y arandela + 2 arandelas	M12x50 mm	Tropicaliz.
4	Bullone completo Bolt with nut and washer, Schraube komplett, Boulon complet, Tornillo completo con tuerca y arandela	M16x30 mm	Tropicaliz.
3	Piastrina copriasola Slot covering plate, Lochabdeckplatte, Plaque de couverture fente, Placa cubre-ranura	100x40x4 mm	S 355 JOWP
2	Palo "C" C-post, C-Steher, Poteau en C, Poste "C"	120x55x30 Th=4 H=1700mm	S 355 JOWP
1	Fascia 2 onde 2-waves beam, 2-wellige Leitschiene, Glissière 2 ondes, Banda doble onda	L=4816 (1500x3) Th=2,85 mm	S 355 JOWP