

CLASSE H2 BORDO PONTE - BARRIERA 3 ONDE PER MANUFATTO W4

Class H2 Bridge side - 3-waves guardrail for bridge W4
 3 Wellen Leitplanke auf Bauwerk, Aufhaltestufe H2, Wirkungsbereich W4
 Classe H2 Bord pont - Glissière 3 ondes simple pour pont W4
 Clase H2 Borde de puente - Barrera de triple onda simple para base puente W4

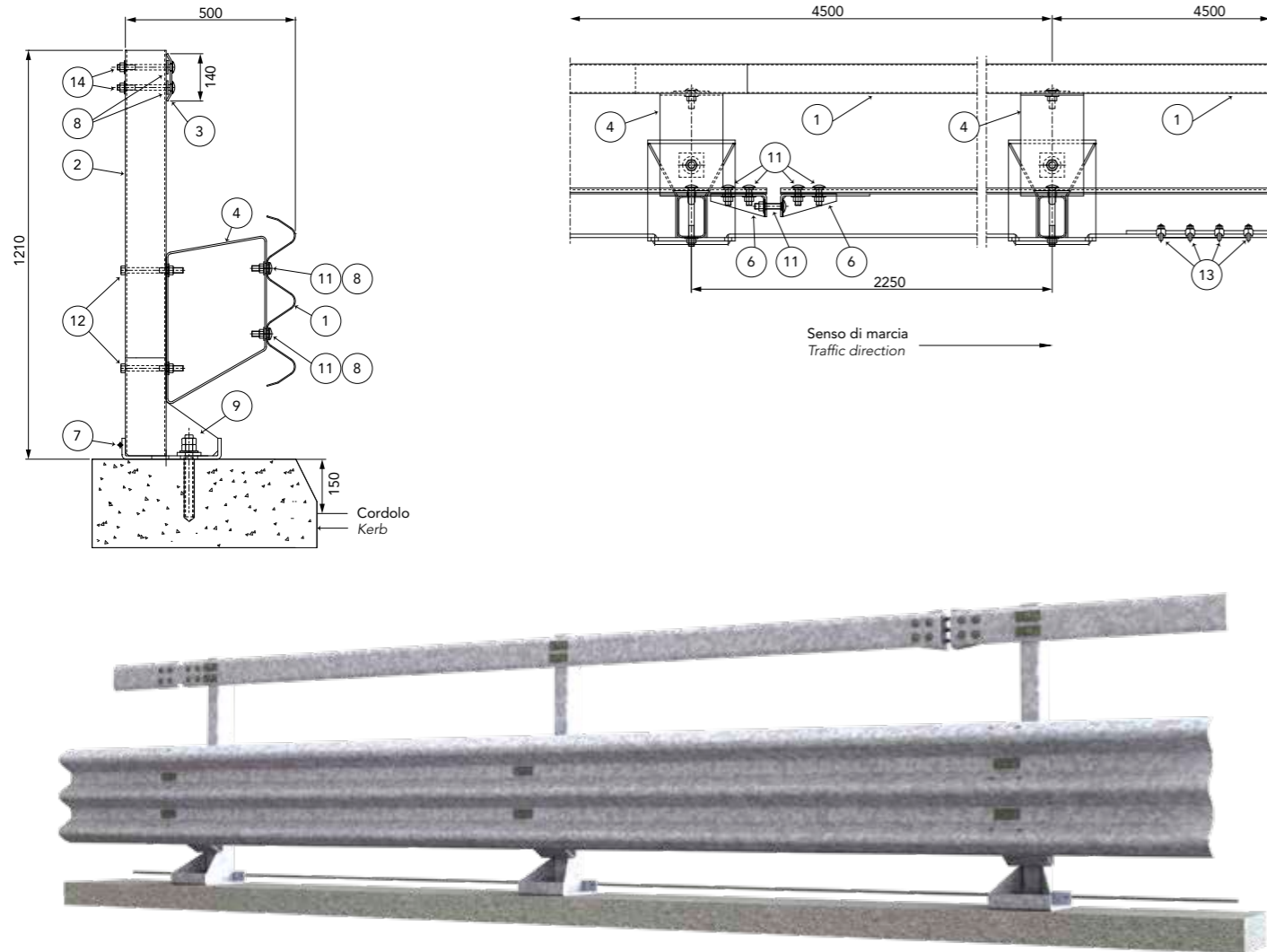

Caratteristiche Characteristics, Eigenschaften, Caractéristiques, Características

Altezza barriera Barrier height, Höhe Leitplanke, Hauteur glissière de sécurité, Altura barrera	1210 mm
Profondità d'infissione tirafondi Depth of anchor bolts penetration, Einschraubtiefe der Verankerungen, Prondeur de vissage des ancrages, Profundidad de anclaje varilla roscada	255 mm
Ingombro trasversale Overall width, Gesamtbreite, Grosseur hors tout, Anchura total	500 mm
Interasse pali Post spacing, Steherabstand, Distance entre poteaux, Distancia entre postes	2250 mm

Rapporti di prova Crash test reports, Testberichte, Comptes rendus d'essais, Relaciones de pruebas

Test n.	Facility	Test	Type	Barrier length m	Mass kg	Speed km/h	ASI max 1.4	THIV max 33 km/h	D m	Vi m	W m
X91.04.L03	TÜV	TB51	Laterale 20°	78,75	13.000	70	-	-	1	1,2	1,3=W4
X91.02.L02	TÜV	TB11	Laterale 20°	78,75	900	100	1,2=B	27	0,3	-	0,8=W2

H2-W4

3-waves

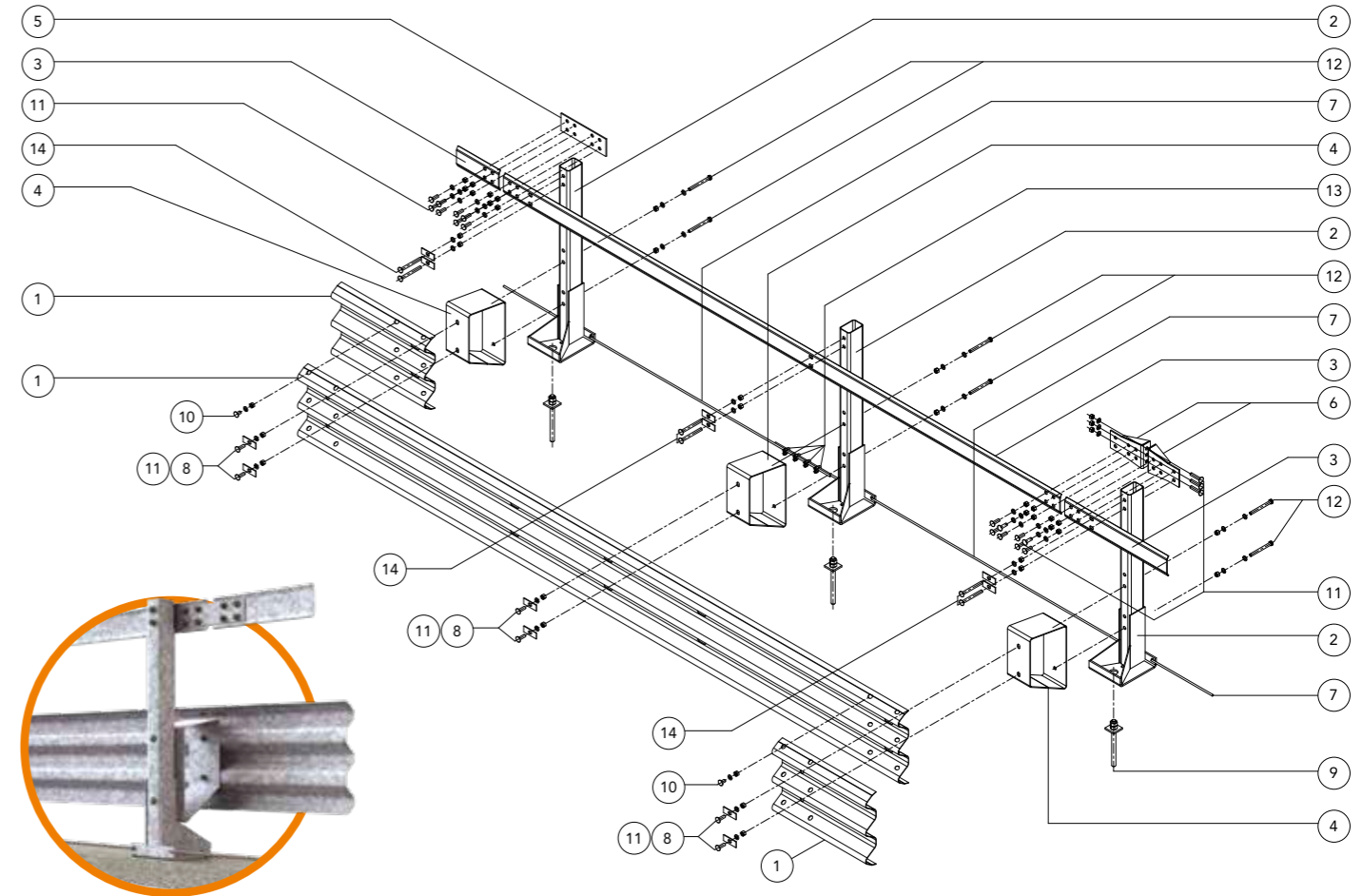

Componenti Components, Bauteile, Composants, Elementos

	Descrizione Description	Materiale Material
13	Morsetto per fune Cable clamp, Schraubklemme für Stahlseil, Serre-câble, Grapa para cable	Acc. zinc.
14		M16x160 mm
12	Bullone completo Bolt with nut and washer, Schraube komplett, Boulon complet, Tornillo completo con tuerca y arandela	M16x170 mm
11		M16x50 mm
10		M16x30 mm
9	Tirafondo + 2 dadi + 1 rondella Anchor bolt + 2 nuts + 1 washer, Verbundklebeankerschraube + 2 Mütter + 1 Unterlegscheibe, Tire-fond + 2 écrous + 1 rondelle, Varilla Roscada + 2 tuercas + 1 arandela	M24x315 mm
8	Piastrina copriasola Slot covering plate, Lochabdeckplatte, Plaque de couverture fente, Placa cubre-ranura	100x40x4 mm
7	Fune Wire rope, Seil, Câble, Cable	Ø12 L=6000 mm
6	Elemento di trazione Traction element, Zugelement, Élément de traction, Elemento de tracción	Th=6 mm
5	Piatto di collegamento Connection plate, Anschlussplatte, Plaque de connexion, Platina de unión	120x360 Th=6 mm
4	Distanziatore romboidale Rhomboidal spacer, Rhomboidisch. Abstandhalter, Entretoise en losange, Separador romboidal	Th=5 mm
3	Bandella superiore Upper shaped plate, Oberer Bandstahl, Barre supérieure, Banda superior	140x4460 Th=5 mm
2	Palo in tubo con piastra Rectangular tube post with base plate, Vierkantrohrsteher mit Grundplatte, Poteau tubulaire avec plaque, Poste de tubo con placa	120x80 Th=4 H=1200 mm
1	Fascia 3 onde 3-waves beam, 3-wellige Leitschiene, Glissière 3 ondes, Banda triple onda	L=4816 (2250x2) Th=2,5 mm